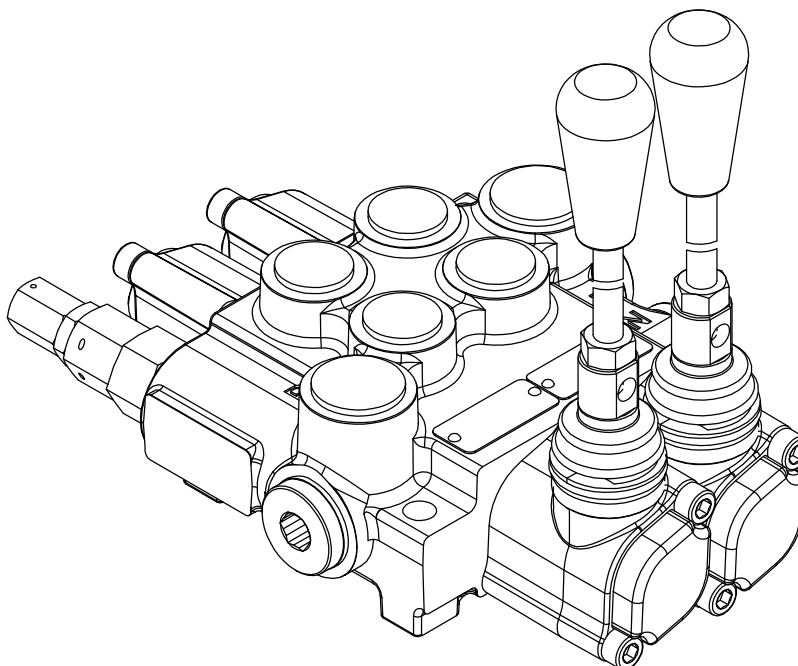

directional control valve Z50

Description

Назначение и применение

For starting, controlling and stopping the working fluid between the generator of pressure flow, the consumers and the Tank. Предназначение для изменения направления потока, ограничения давления рабочей жидкости в гидрелинии, разгрузка насоса в нейтральной позиции золотника.

Specifications

Основные показатели

1. Valve monoblock	моноблок
Конструктивное решение	
2. Mounting	2 bolts M8
Крепление	
3.Ports	internal thread
Присоединительные отверстия	резбовые отверстия
4.Ambient temperature	-40 – +60 C
температура воздуха	
5.Pressure medium	mineral oil
Рабочая жидкость	
6.Viscosity	12...800 mm/s
Вязкость	20...100 mm/s
	recommended range
7.Fluid temperature	-30 – +80 C
8.Filtration	oil contaminations
	class 10 to NAS 1683
	achived with filter 75
9.Max. operating pressure	P = 250 bar
	A, B = 300 bar
	T < 50 bar
10 Internal leakage	5 ccm/min at 100 bar
	viscosity 46 mm/s
11.Nominal flow	40 l/min (operating diagram)
12.Spool stroke	+– 6 mm
13.Actuating force	< 200 N in spool axis

directional control valve Z50

Left hand configuration – standard

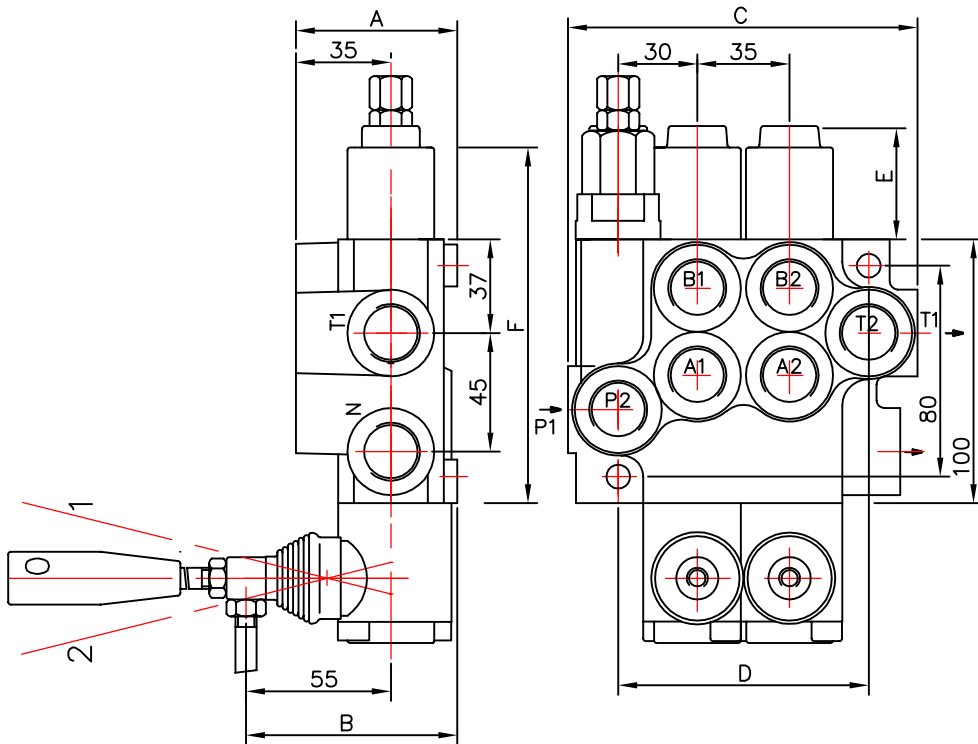

Right hand configuration

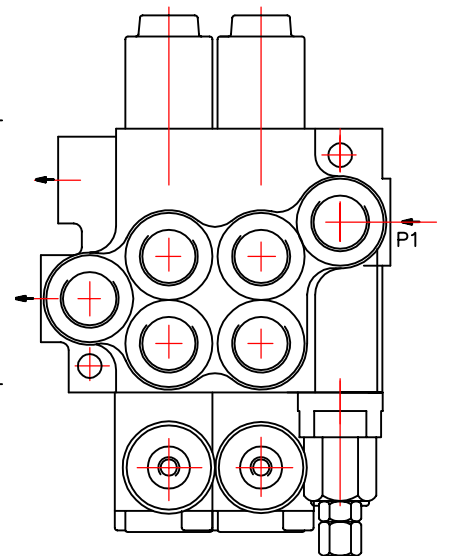

Table 1

	A	B	C	D	P1	P2	T1	T2
01Z50	60	80	85	60	+	-	+	-
02Z50	60	80	129	97	+	+	+	+
03Z50	60	80	164	132	+	+	+	+
04Z50	60	80	199	167	+	+	+	+
05Z50	60	80	234	202	+	+	+	+
06Z50	60	80	269	237	+	+	+	+
07Z50	60	80	304	272	+	+	+	+

Table 2

spool control фиксации золотника	E	F
1; 4; 5; 6; 7; 8; 9; 10; 11;	40	193
2; 3;	72	225
16	+	+

Table 3

code	spools
01	1
02	2
03	3

ets.

- 0 block with common check valve / распределитель с общим клапаном
- 2 number of spools / количество золотников
- Z50 directional control valve type ... / распределитель типа ...
- R inlet high pressure – right / вход давления с правой стороны
- A first spool distribution type / характеристика первого золотника
- 1 spool control/detend and ets./ / контроль золотника/фиксации и грузе/
- A second spool distribution type / вид второго золотника
- 1 spool control/detend and estr./ / контроль золотника/фиксации и грузе/
- G ports /treads/ / резьбовые отверстия
- KZ1 general operation feature / вид ручного управления
- T with "teton" / исполнение ручного управления с "тетон"
- H operation feature /pneumatic, .../ / грузе управление
- E with electric switch / с электрическим выключателем
- C2 high pressure carry over / продолжител потока высокого давления
- 11 connection ports in use / присоединительные отверстия

directional control valve Z50

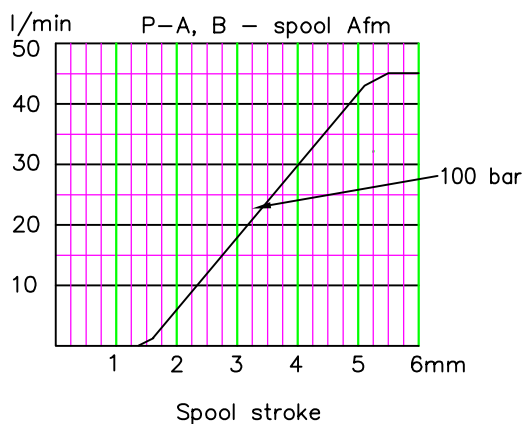
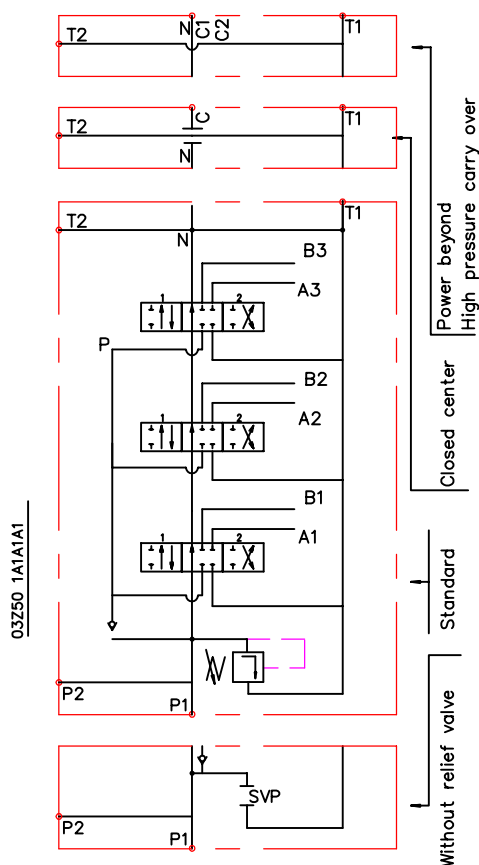

Table 4

code	way of distribution ; распределение потока
1	parallel ; параллельное

Table 5

code	spool type
A	
B	
C	
D	
E	
F	
G	
H	
M	
N	
O	
P	
Q	
R	
S	
T	
K	
L	

Table 6

code	spool control
1	
2	
3	
4	
5	
6	
7	
8	
9	
10	
11	
* 15	
* 16	
** 12	
** 13	

* только при вход слева (dy8) only for left hand configuration

** только при вход справа (dy8) only for right hand configuration

*** Spool Afm – fine metering

Table 7

code	с микро шалтер ; incorporated microswitch
E	 mikroswitch type Omron-V 165 I C5

Table 8

code	другое управление ; operation feature
P	 пневматическое on-off pneumatic control; 5–10 bar ; ports NPTF 1/8–27
H	 гидравлическое on-off hydraulic control ; pn = 5 – 20 bar ; ports G1/4

directional control valve Z50

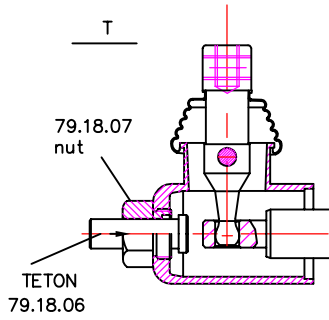

Z50

Table 9

code	ports (treads) ; присоединительные отверстия				
	P	A ; B	T	N	C2
M	M22x1.5	M18x1.5	M22x1.5	M22x1.5	M22x1.5
G	G1/2	G3/8	G1/2	G1/2	G1/2
S	7/8-14UNF	3/4-16UNF	7/8-14UNF	7/8-14UNF	7/8-14UNF

kind of hand control ; вид ручного управления

Table 10

code	ескуз feature	code	ескуз feature	code	ескуз feature
KZ		KY		KI	
KZ1		KY1		KI1	
KZO		KYO		KIO	
KZ01		KY01		KI01	
-	without hand control ; без ричажная система управления				

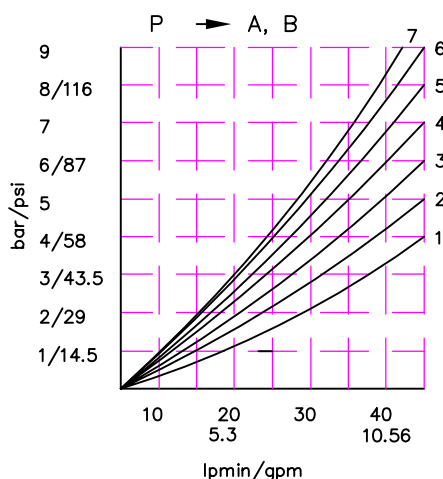
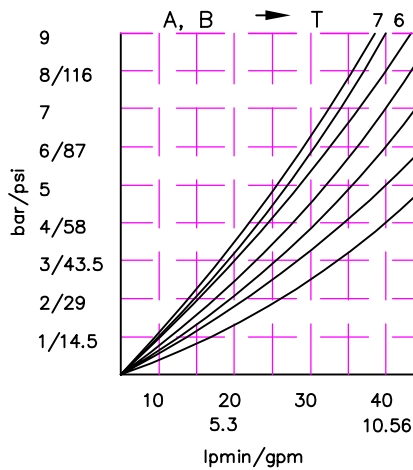
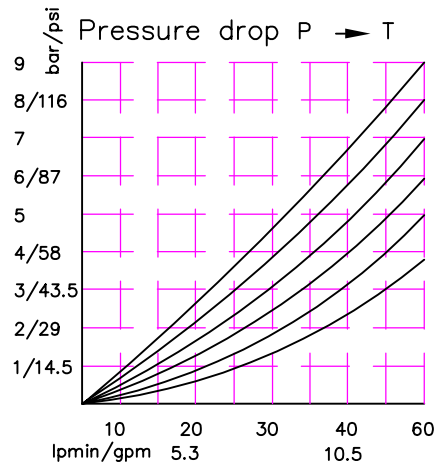

Table 11

code	вид прогължение на дебита	
C	отвор "N" затворен closed center	
C2	отвор "N" прогължава за следващ консуматор part for power beyond sleeve(carry over)	
-	отвор "N" е свързан с "T" without part for pressure carry over	
X	отвор "N" е винаги свързан с "T" power beyond ever to tank	

Table 12

code	used connection ports ; присоединительные отверстия
11	P1 ; T1
12	P1 ; T2
21	P2 ; T1
22	P2 ; T2

REMOTE CONTROLS
Управление тросом

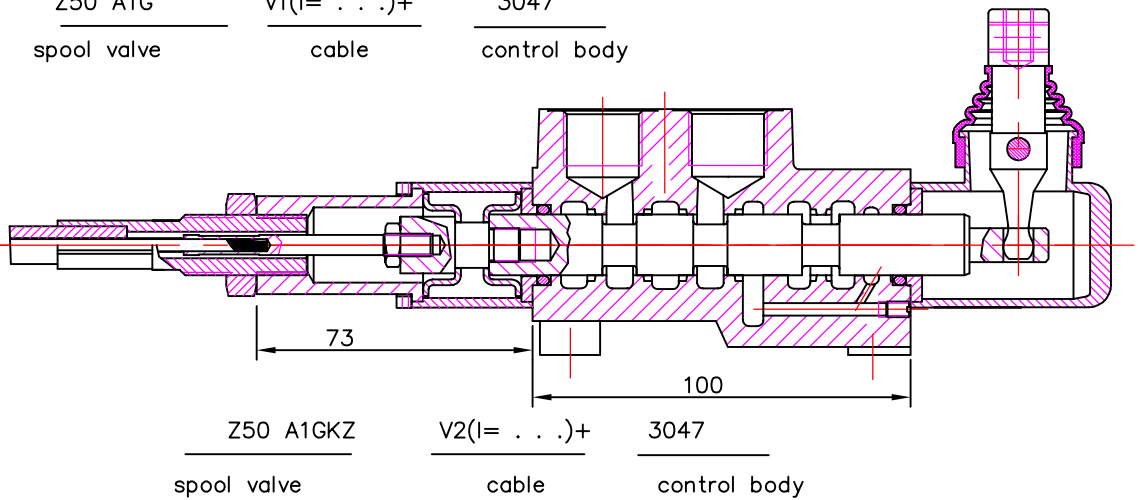
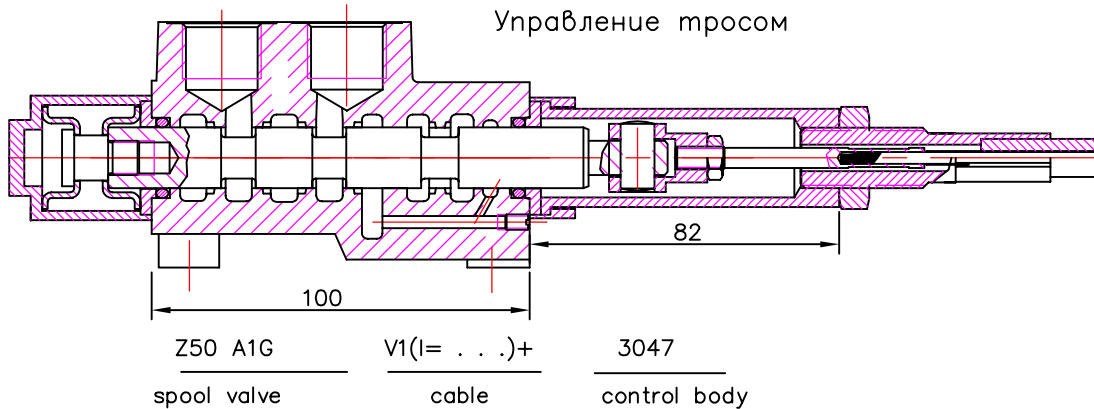

Cable "INDEMAR" Cod. IT 3056 /l=1.00; 1.50; 2.00; 2.50; 3.00 m/
+control body "INDEMAR" code 3047, 3076, 3077

Technical specifications			
	3047	3076	3077
Stroke	13+13 mm	13+13 mm	13+13 mm
Max. load	45 kg	45 kg	45 kg
Level ratio	10:1	10:1	10:1
Lock in neutral	No	No	Yes
Antireverse lock	No	Yes	No
Body colour	Black	Black	Black
Cables type	Heavy Duty	Heavy Duty	Heavy Duty
Operating temperature	-40/+80C	-40/+80C	-40/+80C

High solidity controls for easy mounting on every type of distributor. They can be mounted stand alone or packed together. They use push-pull heavy duty cables that provide a positive smooth operating lever and are manufactured in a three different models to meet different needs of Clients.

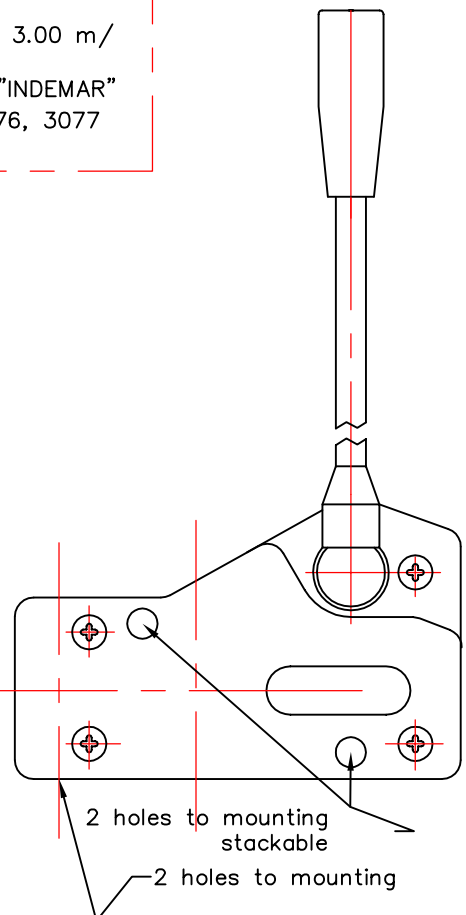

directional control valve 750

JOYSTICK "+"

This control gives the possibility to operate, at the same time two spools with a "+" movement.

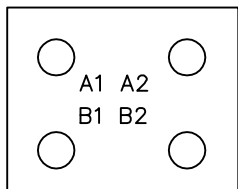
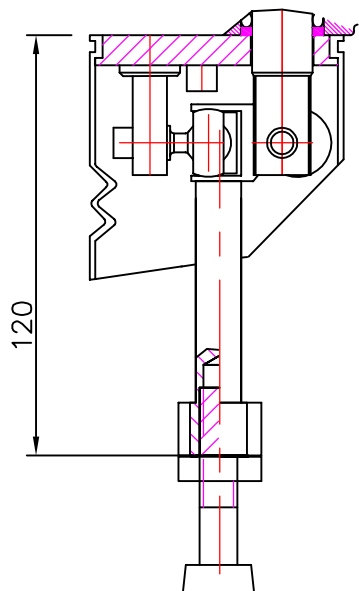

standard version 1

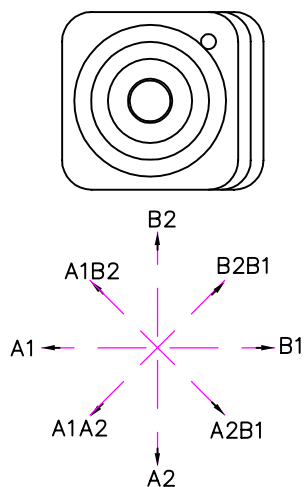

standard version 2

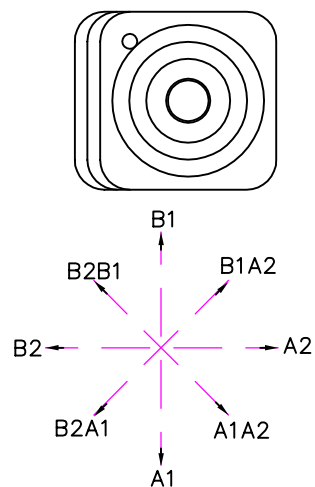

standard version 3

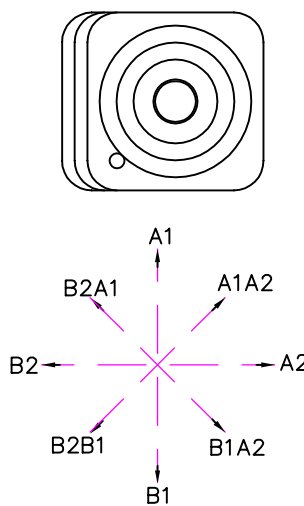

standard version 4

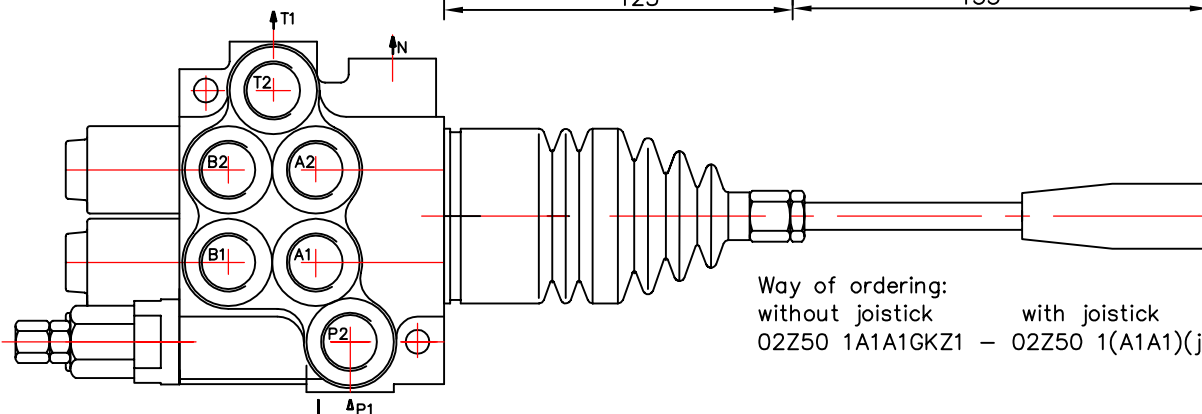
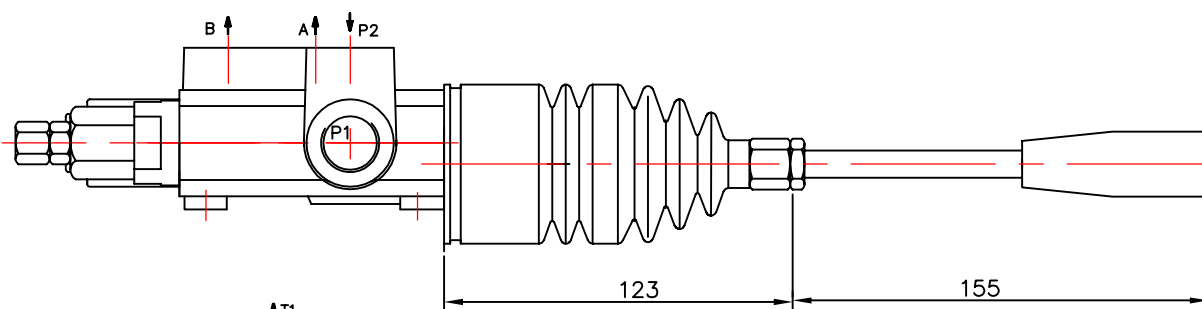
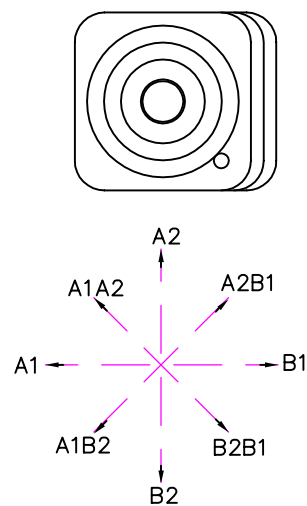

Way of ordering:
without joystick with joystick
02Z50 1A1A1GKZ1 - 02Z50 1(A1A1)(js+3)G

directional control valve Z50

ED3 – electro-hydraulic control ON-OFF
 Электрогидравлический контрол ON-OFF

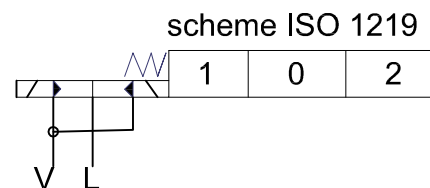
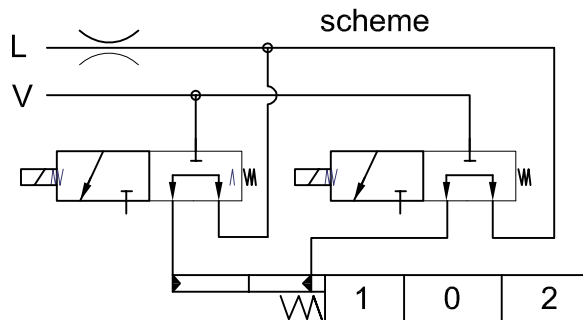
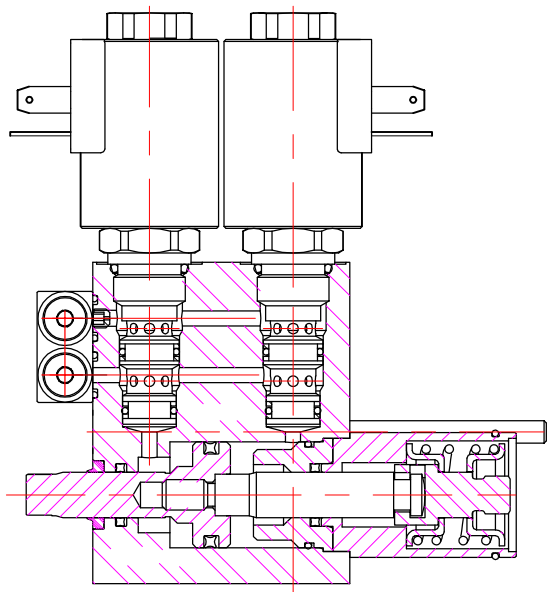

Operating pressure min 10 bar(145 psi)
 max 50 bar(725 psi)
 Max operating pressure in L (T line) 25 bar(360 psi)

Ordering codes
 3-wai solenoid valve-SV08-33
 coil P40ED3-G-12VDC
 coil P40ED3-G-24VDC

Solenoid operating features
 Nominal voltage tolerance ±10%
 Power rating 24W
 Duty cycle 100 %

Collector kit for external pilot and drain – CEED...(1,2,3 ...)
 Коллектор для внешнего питания управления и слив

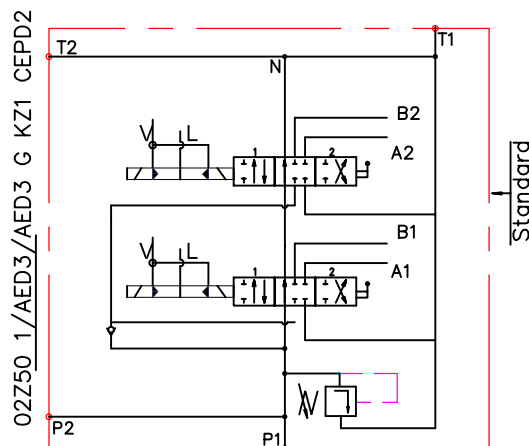
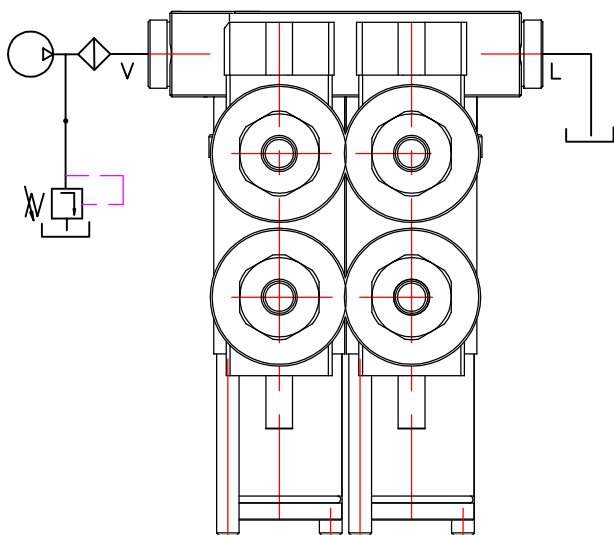

Ordering example

02Z50-1/A1ED3/A1ED3 G KZ1-CEED2-12VDC

Ordering codes (BSP threads)

CEED1P40	Kit for 1 section
CEED2P40	Kit for 2 section
CEED3P40	Kit for 3 section
CEED4P40	Kit for 4 sektion
.....	

directional control valve Z50

ED3 – electro-hydraulic control ON-OFF
 Электрогидравлический контрол ON-OFF

Order codes

3-wai solenoid valve-LSV2-08-3C
 coil P40ED3-G-12VDC
 coil P40ED3-G-24VDC

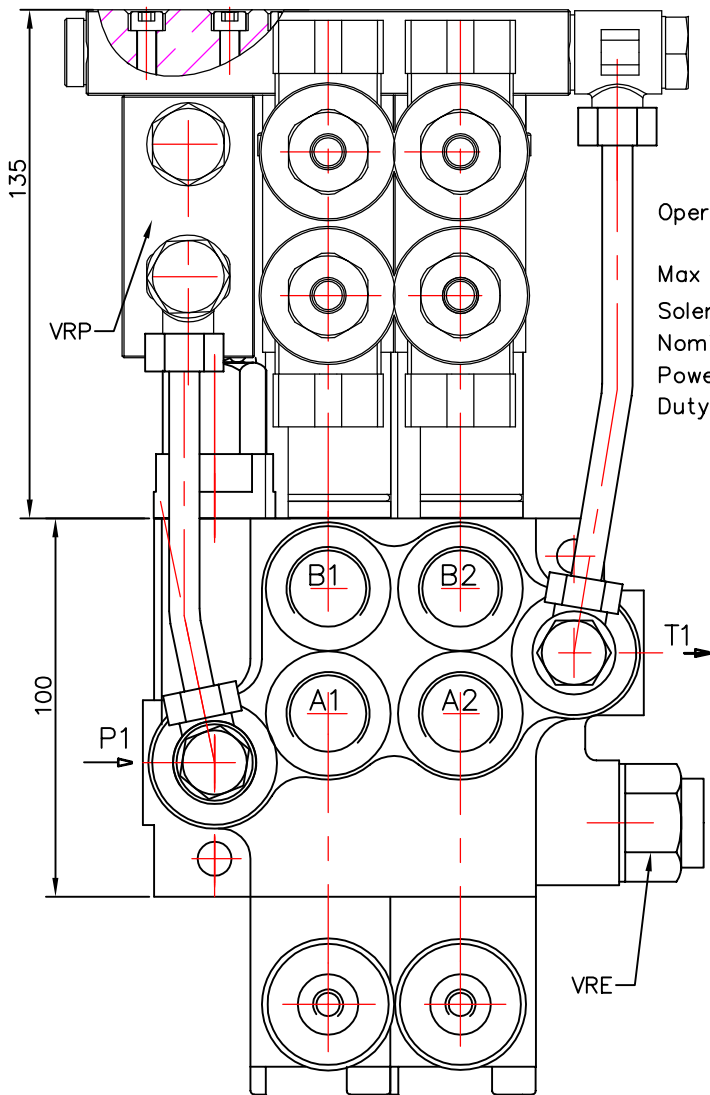

Operating pressure min 10 bar(145 psi)
 max 50 bar(725 psi)
 Max operating pressure in L (T line) 25 bar(360 psi)
 Solenoid operating features
 Nominal voltage tolerance ±10%
 Power rating 24W
 Duty cycle 100 %

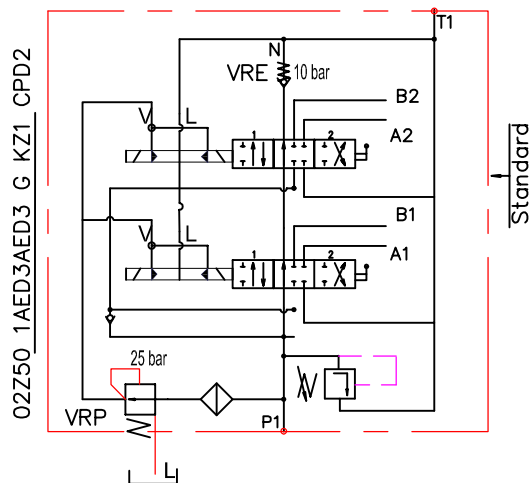

Ordering example

02Z50-VRP- 1/A1ED3/A1ED3 G KZ1-CED2-VRE-12VDC

Colector kit - BSP threads
 Ordering codes

CED1 Kit for 1 section
 CED2 Kit for 2 section
 CED3 Kit for 3 section
 CED4 Kit for 4 sektion

Back pressure valve VRE-P40
 Клапан погпорний на слив

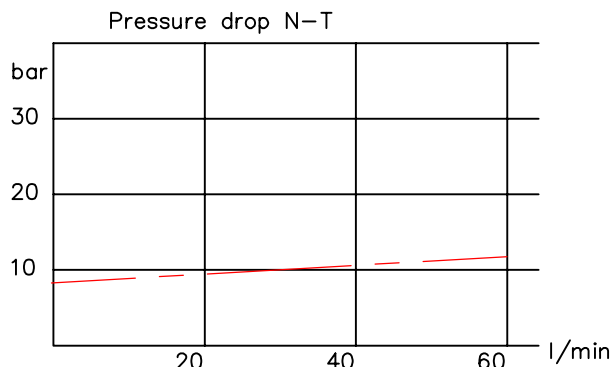
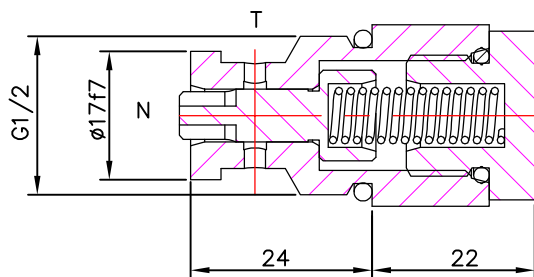

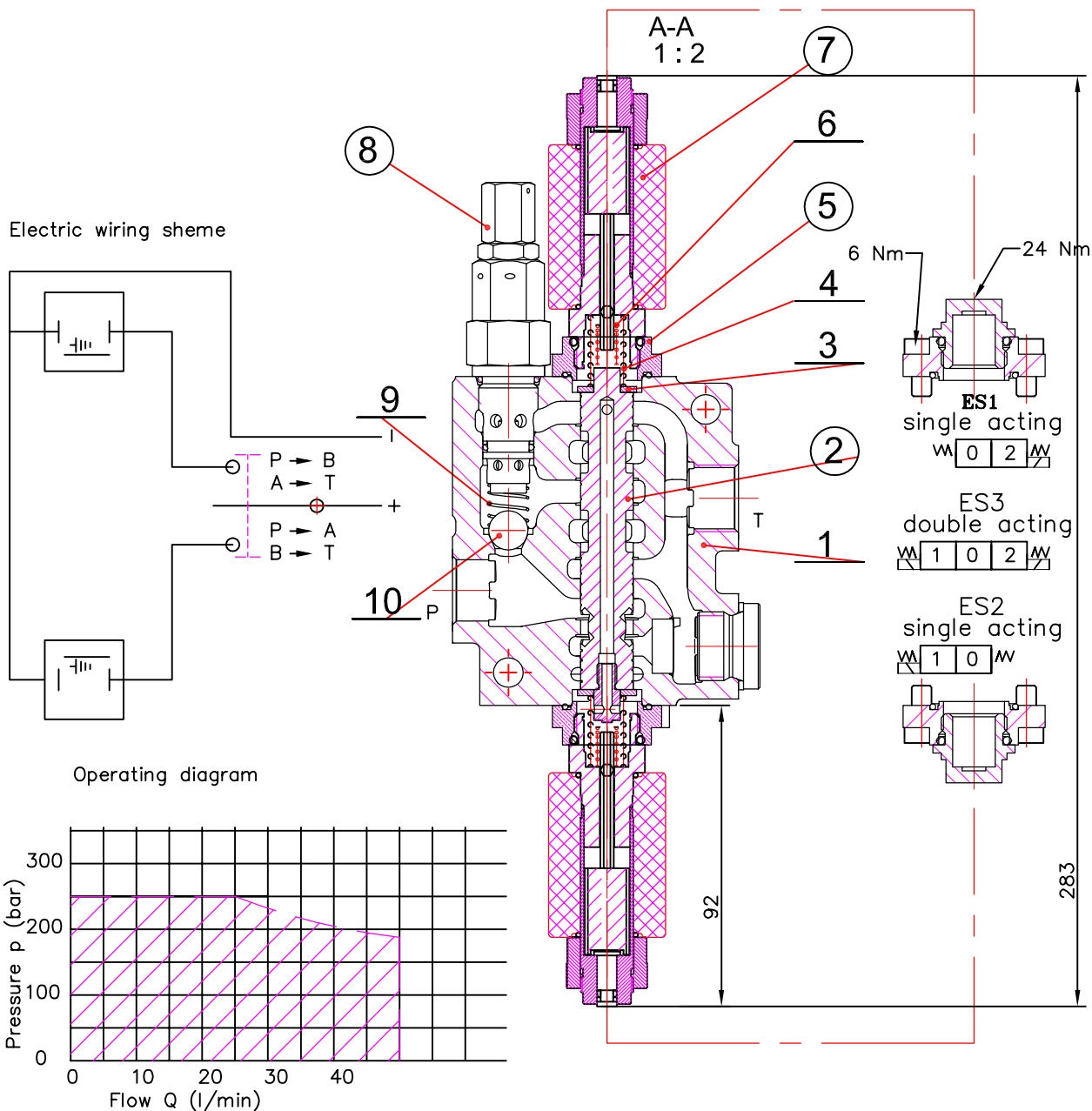

Operating features

Технические примечания

Control

Internal leakage A(B) → T
 (p=120 bar, Viscosity=32 mm²/s : max 30 ccm/min)
 Fluid temperature - -20°C(short time) ... 80°C
 Max. back pressure on outlet port T - 25 bar(360 psi)

Coil

Nominal voltage tolerance ±10%
 Power rating 37 W
 Coil insulation class H
 Duty cycle 100%
 Connector ISO 4400
 lmergency manual override

pos.	Part.No	Description	Quantity
10		Ball 12	1
9	79.00.03	Spring	1
8	79.04.00	Relief valve	1
7b	C35D012RC P01	Solenoid coil	2
7a	GM4060/BD	Solenoid Tube	2
6	542.02.00.07	Additional spring	2
5	542.02.03.00	Intermediate unit	2
4	542.02.00.04	Spring	2
3	542.02.00.02	Washer	2
2		Spool ...	1
1		Body ...	1

Solenoid direct control with spring return to neutral position.
Needs special spools and special body Z50.

ORDERING EXAMPLE

Z50	A	ES3	12VDC	G
1	2	3	4	5

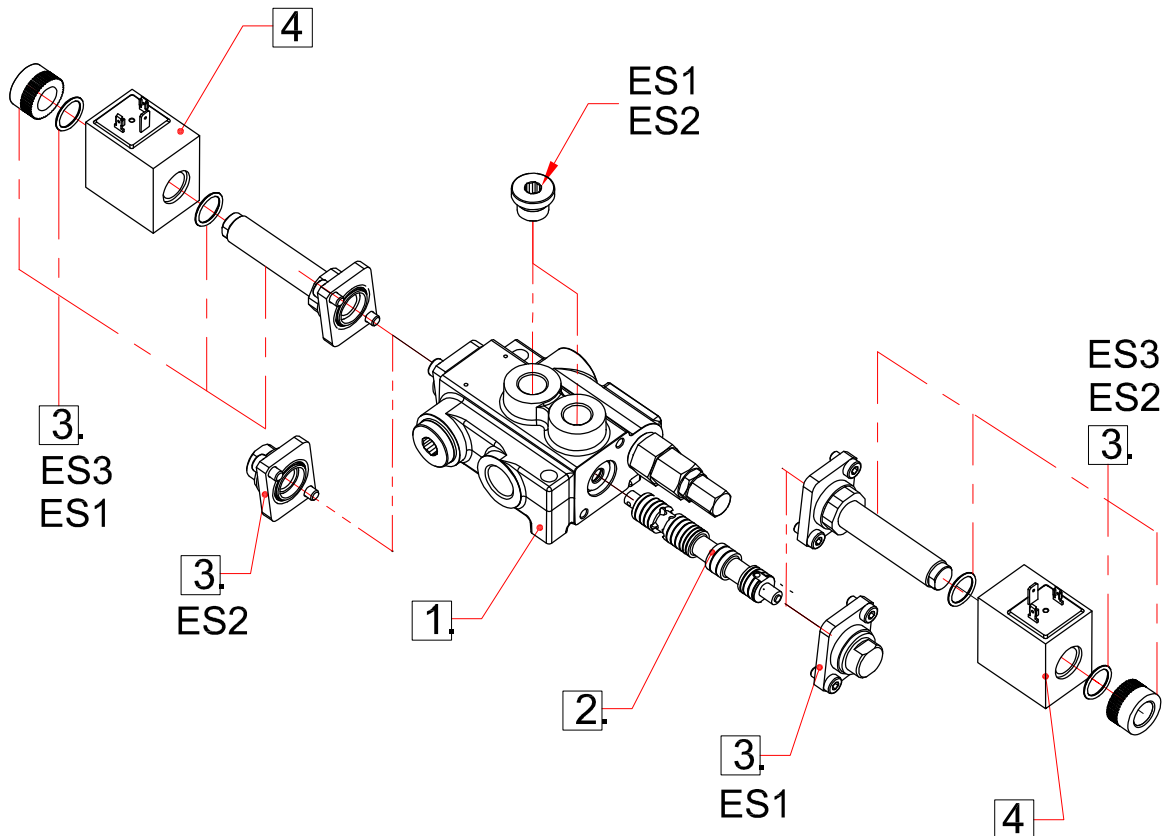

1.Body kit

Type	Description
Z50	1 spool
02Z50	2 spool
03Z50	3 spool
04Z50	4 spool
05Z50	5 spool
06Z50	6 spool

2.Spool options

Type	Description
A	Double acting, 3 positions with A and B closed in neutral position
D	Double acting, 3 positions with A and B open to Tank in neutral position

3.Control kit

Type	Description
ES1	Single acting P – A with spring return in neutral position
ES2	Single acting P – B with spring return in neutral position
ES3	Double acting P – A (B) with spring return in neutral position

4.Coils

Type	Description
(with connector ISO 4400)	
12VDC	Nominal voltage 12VDC
24VDC	Nominal voltage 24VDC

5.Threads

G P, T – G1/2; A, B – G3/8

HYDRAULIC DIRECTIONAL CONTROL VALVES
 РАСПРЕДЕЛИТЕЛИ ГИДРАВЛИЧЕСКИЕ

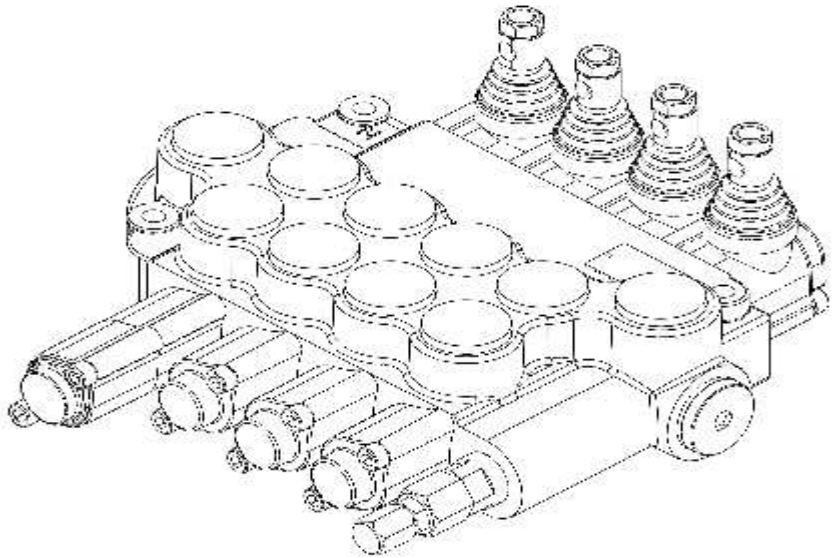

Description

Назначение и область применения

For starting, controlling and stopping the working fluid between the generator of pressured flow, the consumers and the Tank. Предназначен для изменения направления потока, ограничения давления рабочей жидкости в гидрелиниях, разгрузки насоса в нейтральной позиции золотников.

Specifications / Основные показатели

1. Valve monoblock	моноблок
Конструктивное выполнение	
2. Mounting / Крепление	3 bolts M8
3. Pressure connections / присоединительные отверстия	internal threads
4. Ambient temperature	-40 - +60°C
Температура воздуха	
5. Medium	mineral oil based hydraulic oil
Рабочая жидкость	
6. Viscosity	12 - 800 mm ² /s permissible range
Кинематическая вязкость	20 - 100 mm ² /s recommended range
7. Fluid temperature	-20 - +80°C
8. Filtration	Oil contamination 10 to NAS 1683
9. Max. operating pressure	P = 250 bar
	A, B = 300 bar
	T < 50 bar
	6 ccm/min at 100 bar
10. Internal leakage at 46 mm ² /s	
A, B to T	
11. Nominal flow	80 l/min
12. Spool stroke	± 7 mm
Ход золотника	
13. Actuating force	< 220 N in spool axis direction

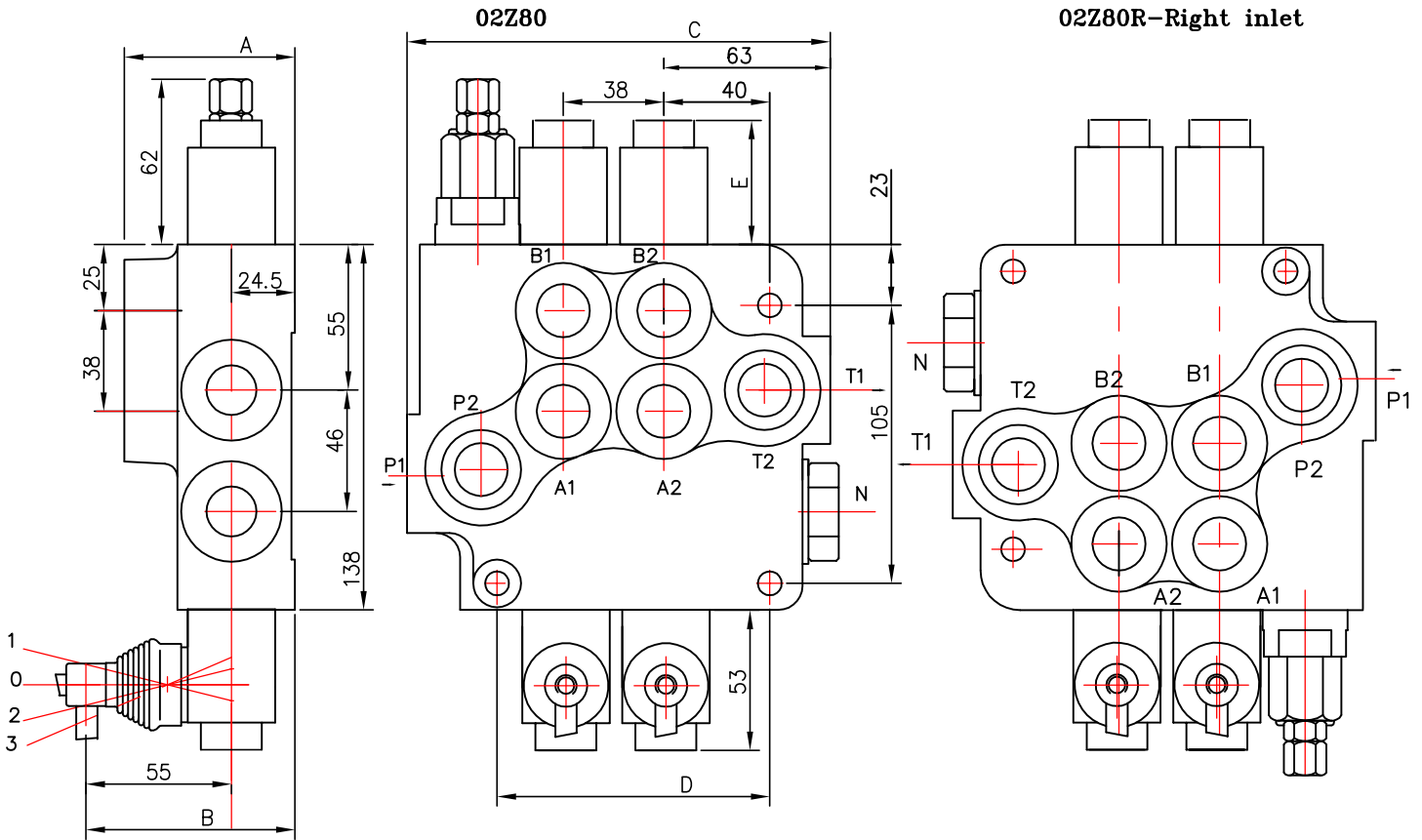

Table 1

	A	B	C	D	P1	P2	T1	T2
01Z80	67	80	122	65	*	*	-	-
02Z80	67	80	160	103	*	*	*	*
03Z80	67	80	198	141	*	*	*	*
04Z80	67	80	236	179	*	*	*	*
05Z80	67	80	274	217	*	*	*	*
06Z80	67	80	312	255	*	*	*	*

Table 2

Spool control	E
1, 4, 5, 6, 7, 8, 9, 10, 11,	40
2, 3, 12, 14	72
13	44

0 _____
 block with common check valve
 распределитель с общим клапаном

2 _____
 number of spools
 количество золотников

Z80 _____
 directional control valve type ...
 распределитель типа ...

R _____
 inlet high pressure – right
 вход давления с правой стороны

A _____
 first spool distribution type
 характеристика первого золотника

1 _____
 spool control/detend and estr./
 контрол золотника/фиксация и грузе/

A _____
 second spool distribution type
 вид второго золотника

1 _____
 spool control/detend and estr./
 контрол золотника/фиксация и грузе/

G _____
 ports/treads/
 резьбовые отверствия

KZ1 _____
 general operation featur
 вид ручного управления

T _____
 with "teton"
 исполнение ручного управления с "тетон"

P _____
 operation featur /pneumatic, .../
 грузе управление

E _____
 with electric switch
 с электрическим выключателем

C2 _____
 high pressure carry over
 продолжител потока високого давления

11 _____
 connection ports in use
 присоединительные отверствия

way of distribution – parallel; распределение – параллельное

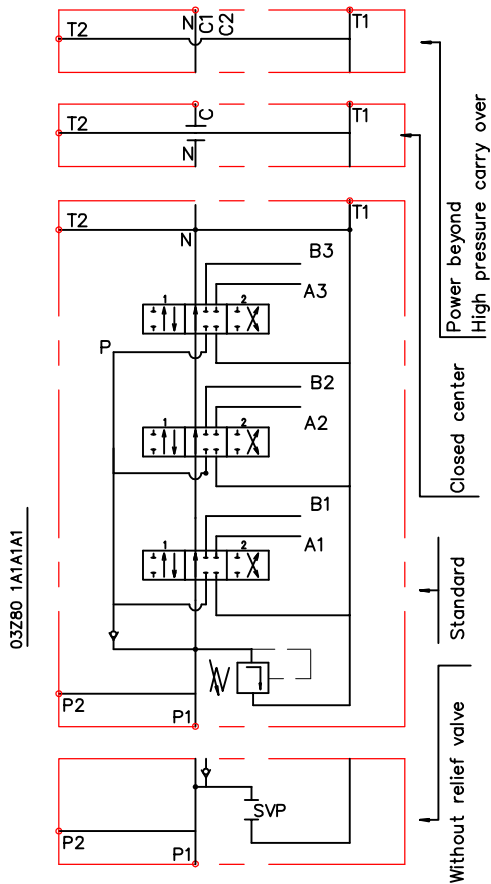

Table 3

code	spool type
A	
B	
C	
D	
E	
F	
G	
H	
M	
N	
O	
P	
Q	
R	
S	
T	
L	

Table 4

code	spool control
1	
2	
3	
4	
5	
6	
7	
8	
9	
10	
11	
12	
13	

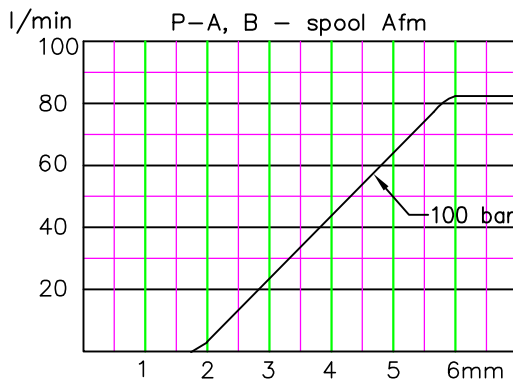
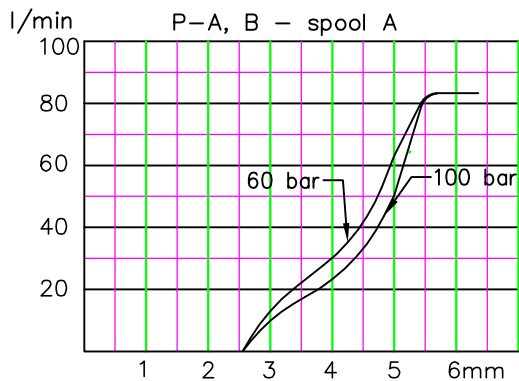

Table 5

code	с микро шалтер ; incorporated microswitch	
E		mikroswitch type Omron-V 165 I C5

Table 6

code	грузое управление ; operation feature	
P		пневматическое on-off pneumatic control; 5–10 bar ; ports NPTF 1/8–27
H		гидравлическое on-off hydraulic control ; pn = 5 – 20 bar ; ports G1/4

directional control valve ..Z80

Z80

Table 7

code	ports (treads) ; присоединительные отверствия				
	P	A ; B	T	N	C2
M	M22x1.5	M22x1.5	M26x1.5	M26x1.5	M26x1.5
G	G1/2	G1/2	G3/4	G3/4	G3/4
S	7/8-14UNF	7/8-14UNF	1 1/16-14UNF	1 1/16-14UNF	1 1/16-14UNF

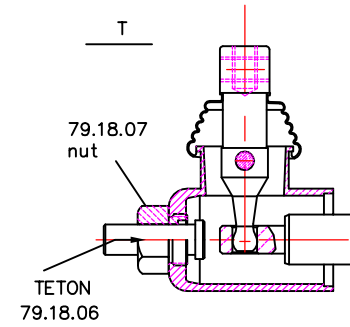

kind of hand control ; вид ручного управления

Table 10

code	ескиз feature	code	ескиз feature	code	ескиз feature
KZ		KY		KI	
KZ1		KY1		KI1	
KZ0		KY0		KI0	
KZ01		KY01		KI01	
_	without hand control ; без ричажная система управления				

Table 11

code	вид продължение на дебита	
C	отвор "N" затворен closed center	
C2	отвор "N" продължава за следващ консуматор part for power beyond sleeve(carry over)	
-	отвор "N" е свързан с "T" without part for pressure carry over	
X	отвор "N" е винаги свързан с "T" power beyond ever to tank	

Table 12

code	used connection ports ; присоединительные отверствия
11	P1 ; T1
12	P1 ; T2
21	P2 ; T1
22	P2 ; T2

..Z80 directional control valve – A

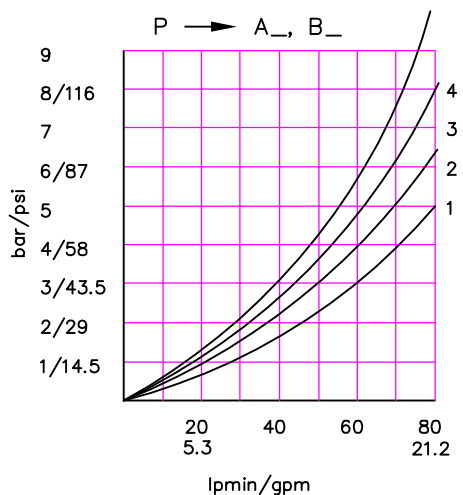
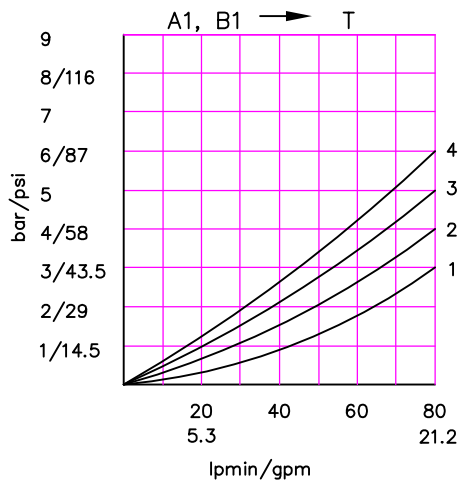
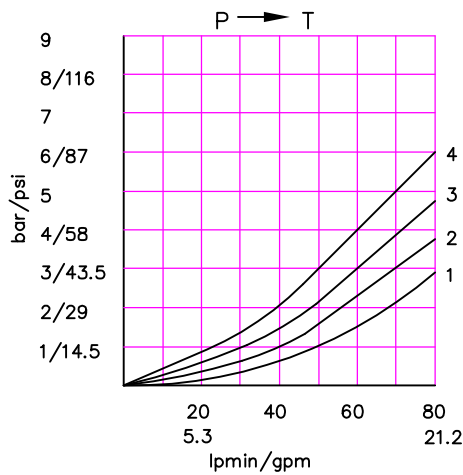

REMOTE CONTROL
Управление тросом

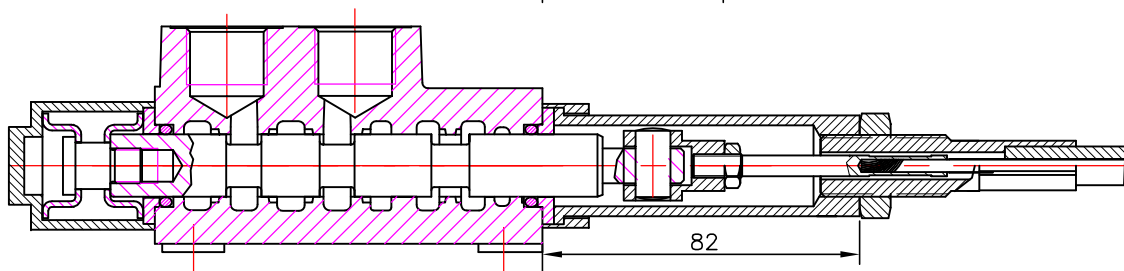

Z80 A1G V1(l= . . .)+ 3047
spool valve cable control body

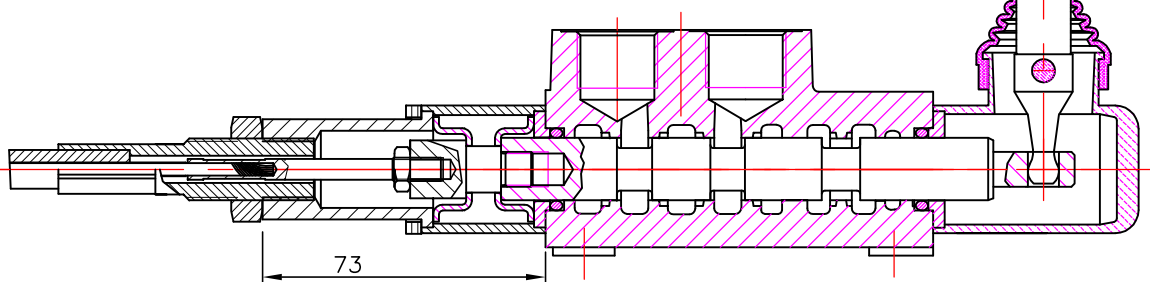

Z80 A1G V2KZ1(l= . . .)+ 3047
spool valve cable control body

Cable "INDEMAR" Cod. IT 3056 /l=1.00; 1.50; 2.00; 2.50; 3.00 m/
+control body "INDEMAR"
code 3047, 3076, 3077

Technical specifications			
	3047	3076	3077
Stroke	13+13 mm	13+13 mm	13+13 mm
Max. load	45 kg	45 kg	45 kg
Level ratio	10:1	10:1	10:1
Lock in neutral	No	No	Yes
Antireverse lock	No	Yes	No
Body colour	Black	Black	Black
Cables type	Heavy Duty	Heavy Duty	Heavy Duty
Operating temperature	-40/+80C	-40/+80C	-40/+80C

High solidity controls for easy mounting on every type of distributor. They can be mounted stand alone or packed together.

They use push-pull heavy duty cables that provide a positive smooth operating lever and are manufactured in a three different models to meet different needs of Clients.

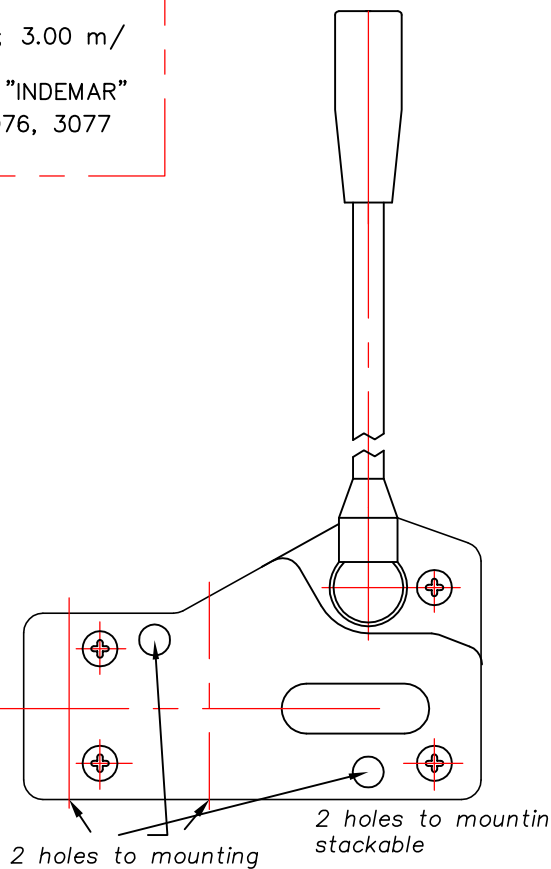

JOYSTICK "+"

This control gives the possibility to operate, at the same time two spools with a "+" movement.

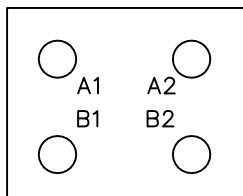
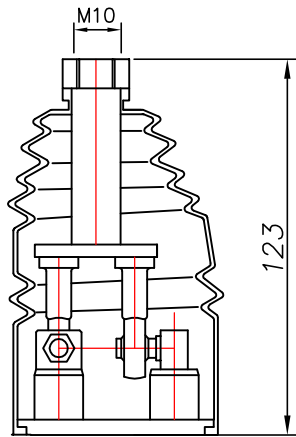

standard version 1

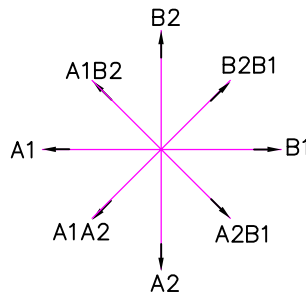
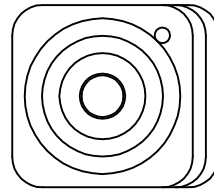

standard version 2

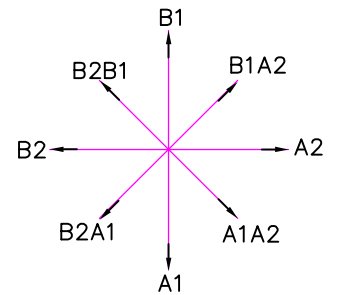
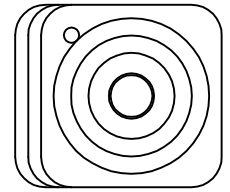

standard version 3

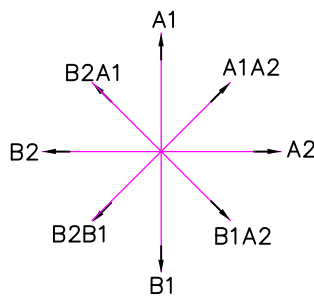
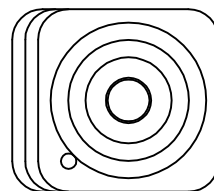

standard version 4

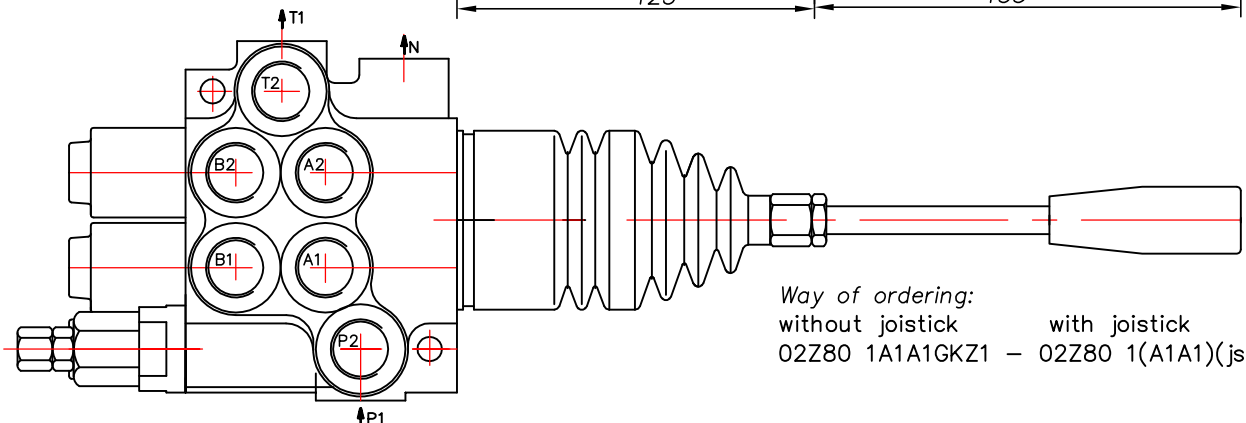
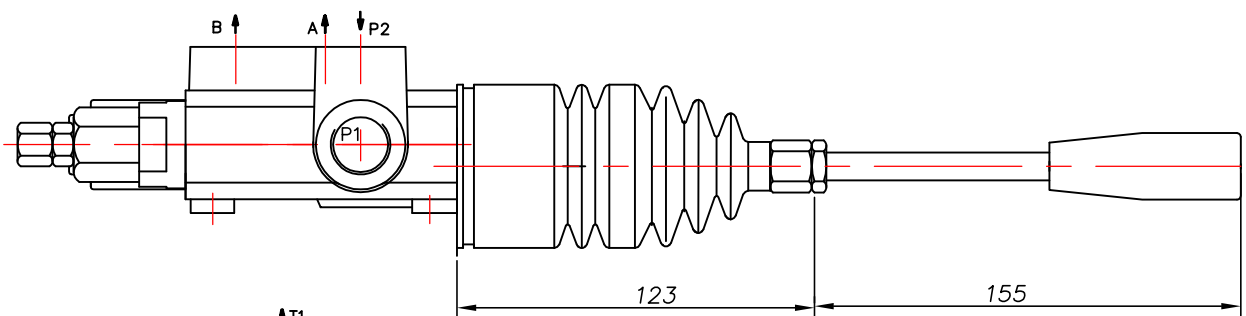
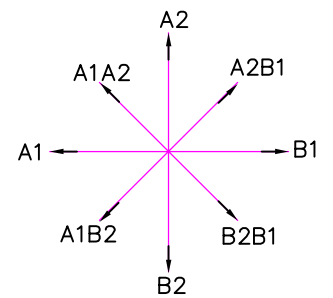
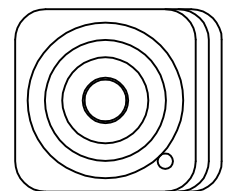

Way of ordering:
 without joystick with joystick
 02Z80 1A1A1GKZ1 - 02Z80 1(A1A1)(js+3)G

directional control valve ..Z80

ED3 – electro-hydraulic control ON-OFF
 Электрогидравлический контрол ON-OFF

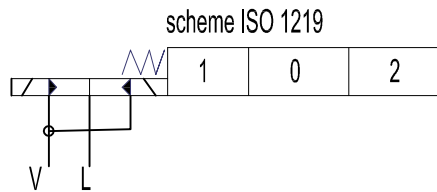
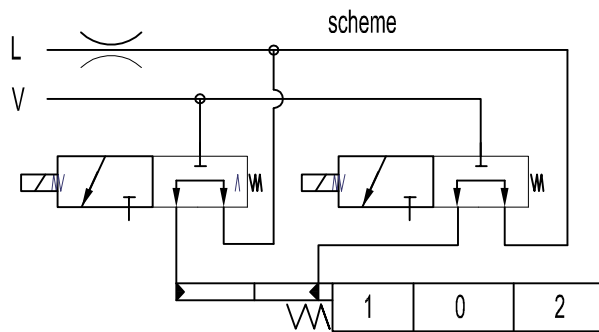
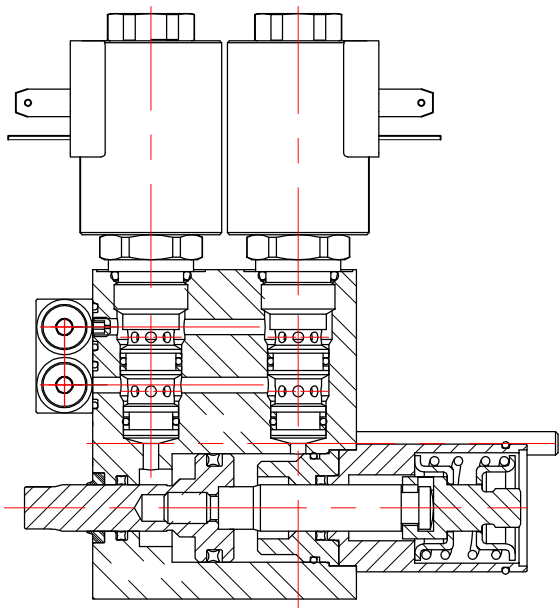

Ordering codes
 3-way solenoid valve-SV08-33
 coil P40ED3-G-12VDC
 coil P40ED3-G-24VDC

Operating pressure min 10 bar(145 psi)
 max 50 bar(725 psi)
 Max operating pressure in L (T line) 25 bar(360 psi)

Solenoid operating features
 Nominal voltage tolerance ±10%
 Power rating 24W
 Duty cycle 100 %

Collector kit for external pilot and drain – CEED...(1,2,3 ...)
 Коллектор для внешнего питания управления и слив

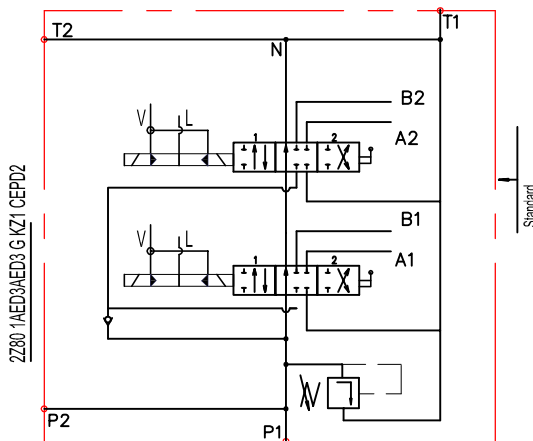
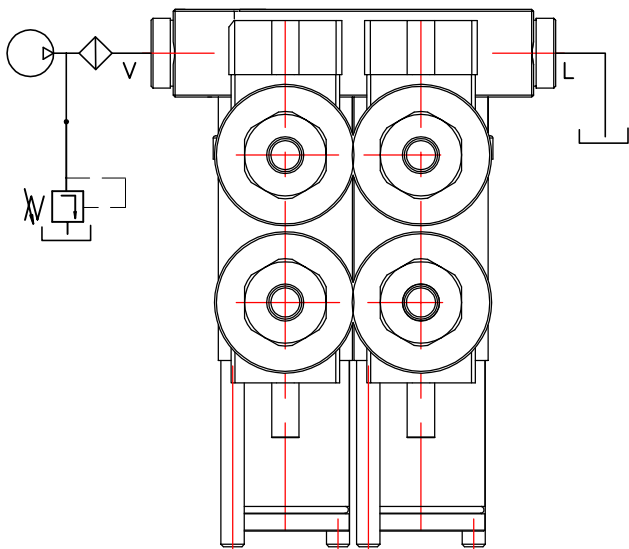

Ordering example
 02Z80 1A1ED3A1ED3 G KZ1-CEED2-12VDC

Ordering codes (BSP threads)

CEED1P80	Kit for 1 section
CEED2P80	Kit for 2 section
CEED3P80	Kit for 3 section
CEED480	Kit for 4 sektion
...	

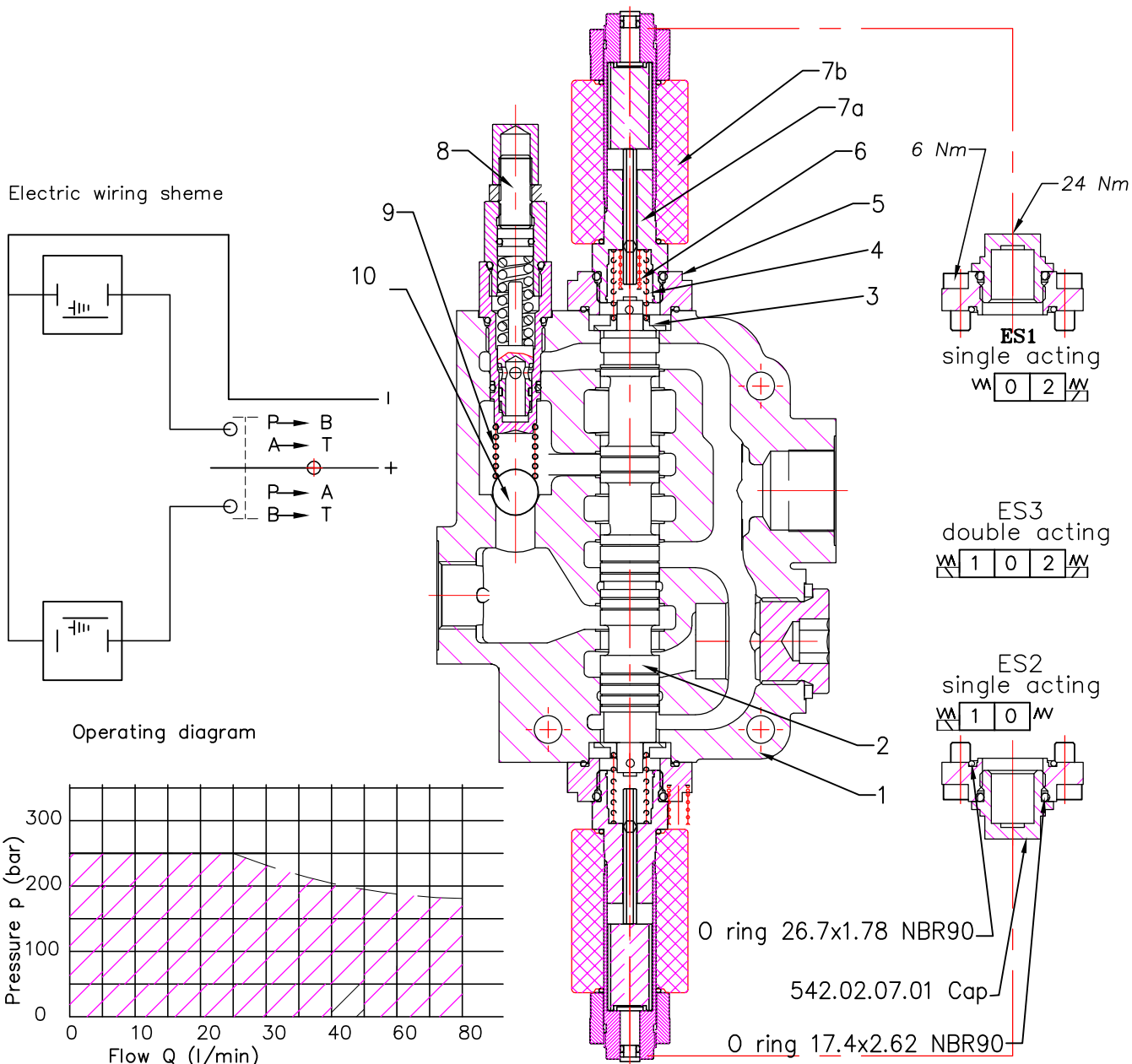

Operating features

Технические примечания

Control

Internal leakage A(B) → T
 (p=120 bar, Viscosity=32 mm²/s : max 40 ccm/min)
 Fluid temperature – –20°C(short time) ... 80°C
 Max. back pressure on outlet port T – 25 bar (360psi)

Coil

Nominal voltage tolerance ±10%
 Power rating 37 W
 Coil insulation class H
 Duty cycle 100%
 Connector ISO 4400
 Emergency manual override

pos.	Part.No	Description	Quantity
10		Ball 14.28	1
9	123.00.47	Spring	1
8	79.04.00	Relief valve	1
7b	C35D012RC P01	Solenoid coil	2
7a	GM4060/BD	Solenoid Tube	2
6	542.02.00.07	Additional spring	2
5	511.02.02.00	Intermediate unit	2
4	542.02.00.04	Spring	2
3	511.02.00.02	Washer	2
2		Spool ...	1
1		Body ...	1

Solenoid direct control with spring return to neutral position.
Needs special spools and special body Z80.

ORDERING EXAMPLE

Z80	A	ES3	12VDC	G
1	2	3	4	5

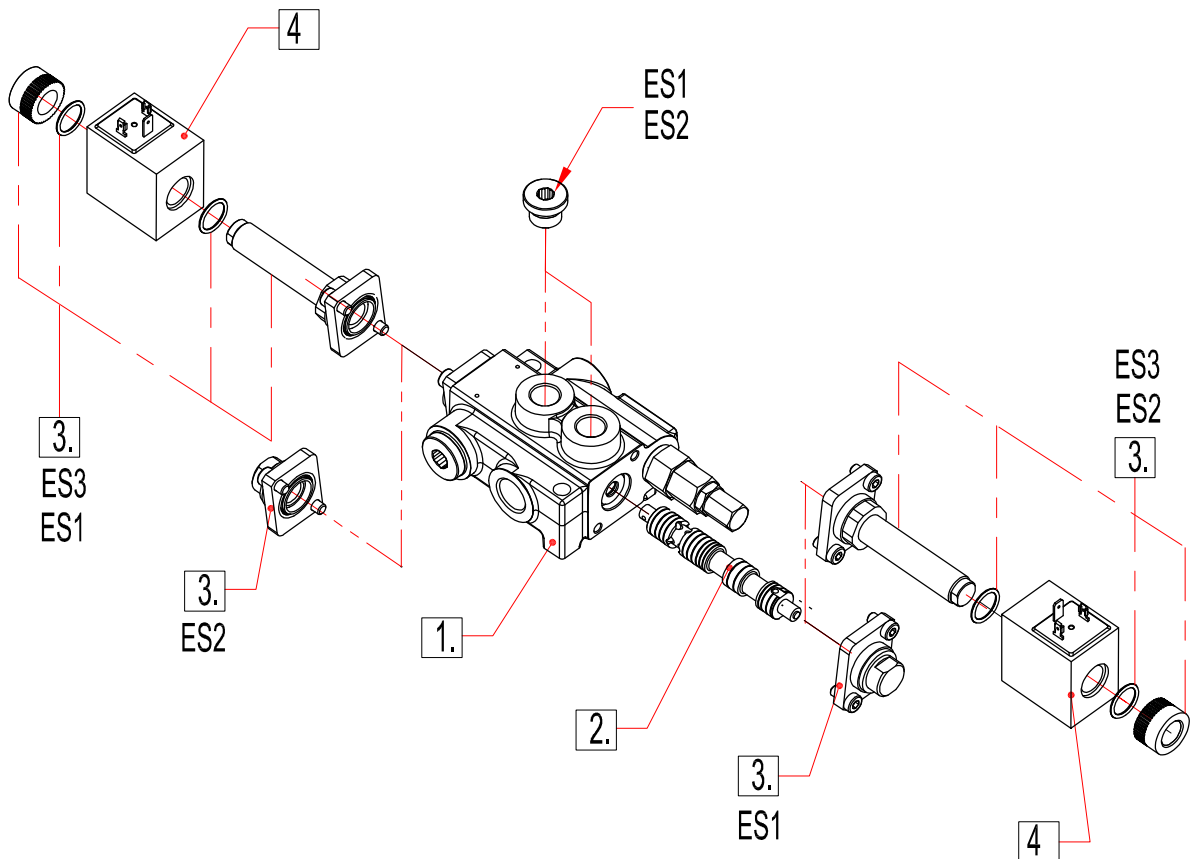

1.Body kit

Type	Description
01Z80	1 spool
02Z80	2 spool
03Z80	3 spool
04Z80	4 spool
05Z80	5 spool
06Z80	6 spool

2.Spool options

Type	Description
A	Double acting, 3 positions with A and B closed in neutral position
D	Double acting, 3 positions with A and B open to Tank in neutral position

3.Control kit

Type	Description
ES1	Single acting P – A with spring return in neutral position
ES2	Single acting P – B with spring return in neutral position
ES3	Double acting P – A (B) with spring return in neutral position

4.Coils

Type	Description
(with connector ISO 4400)	
12VDC	Nominal voltage 12VDC
24VDC	Nominal voltage 24VDC

5.Threads

G	P, T – G3/4; A, B – G1/2
---	--------------------------